

# TPX™

## CONTROL MOUNT INSTALLATION

ADAPTIV™  
TECHNOLOGIES

### CONTENTS

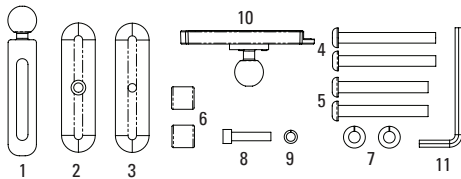

Item No.	Name	Qty.
1	Control Mount Base	1
2	Left Link	1
3	Right Link	1
4	Control Screw (Standard)	2
5	Control Screw (Metric)	2
6	Control Spacer	2
7	Control Lock Washer	2
8	Positioning Screw	1
9	Positioning Lock Washer	1
10	Mounting Plate	1
11	5/32" Hex Key	1

This Mount is designed for most motorcycles with clutch, front brake, or brake reservoir control screws up to 1-9/16" apart, including most Touring, American and Metric Cruisers, and some and Sport bikes.



**Warning:** Installation of the Mount should be performed by a qualified technician. Improper installation may interfere with the safety and proper operation of the product and/or vehicle.

1. Place the motorcycle on a center stand.
2. Remove the two stock clutch, front brake, or brake reservoir screws from the Control Assembly as shown in **Figure 1**.

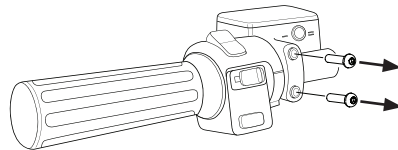

Figure 1

3. Using the 5/32" Hex Key, remove the *Positioning Screw* and *Positioning Lock Washer* to disassemble the Mount as shown in **Figure 2**.

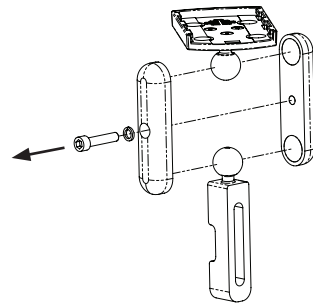

Figure 2

4. Using the  $5/32$ " Hex Key, fasten the *Control Mount Base* to the *Control Assembly* using the supplied *Control Spacers*, *Control Screws* and *Control Lock Washers* as shown in **Figure 3**.

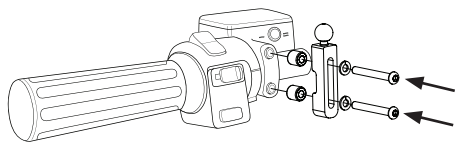

Figure 3

5. Using the  $5/32$ " Hex Key, loosely reassemble the top portion of the Mount as shown in **Figure 4**.



**Tip:** Wiring may be routed in between *Links* to aid in cable management.

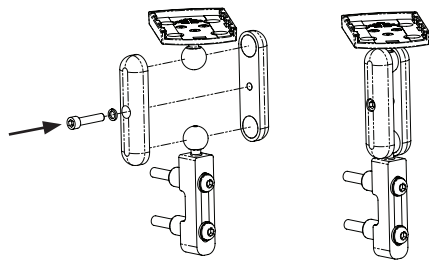

Figure 4

6. Slide the *Main Console* (sold separately) onto the *Mounting Plate* as shown in **Figure 5**.

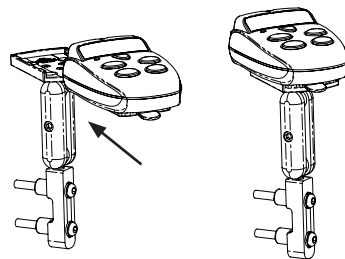

Figure 5

7. Adjust the *Main Console* and *Mount* to the desired position and tighten the *Positioning Screw* to lock the assembly in place.



**Tip:** For optimal performance, the *Main Console* should be horizontal to the ground and should not be obstructed by the gauges.



**Warning:** Verify that the position of the *Main Console* and *Mount* will not interfere with proper operation of the vehicle.



**Warning:** Make sure all screws are securely tightened before each ride so that the assembly will not move during use.

---

**Adaptiv Technologies, LLC**

459 Columbus Avenue  
Suite 709  
New York, NY 10024

[www.RadarForBikes.com](http://www.RadarForBikes.com)

866-ADAPTIV  
(866-232-7848)